

# ASSEMBLY KIT OF AIR OUTLET ON THE FRONT TOP FACE

ShowCave 1 and 2 doors

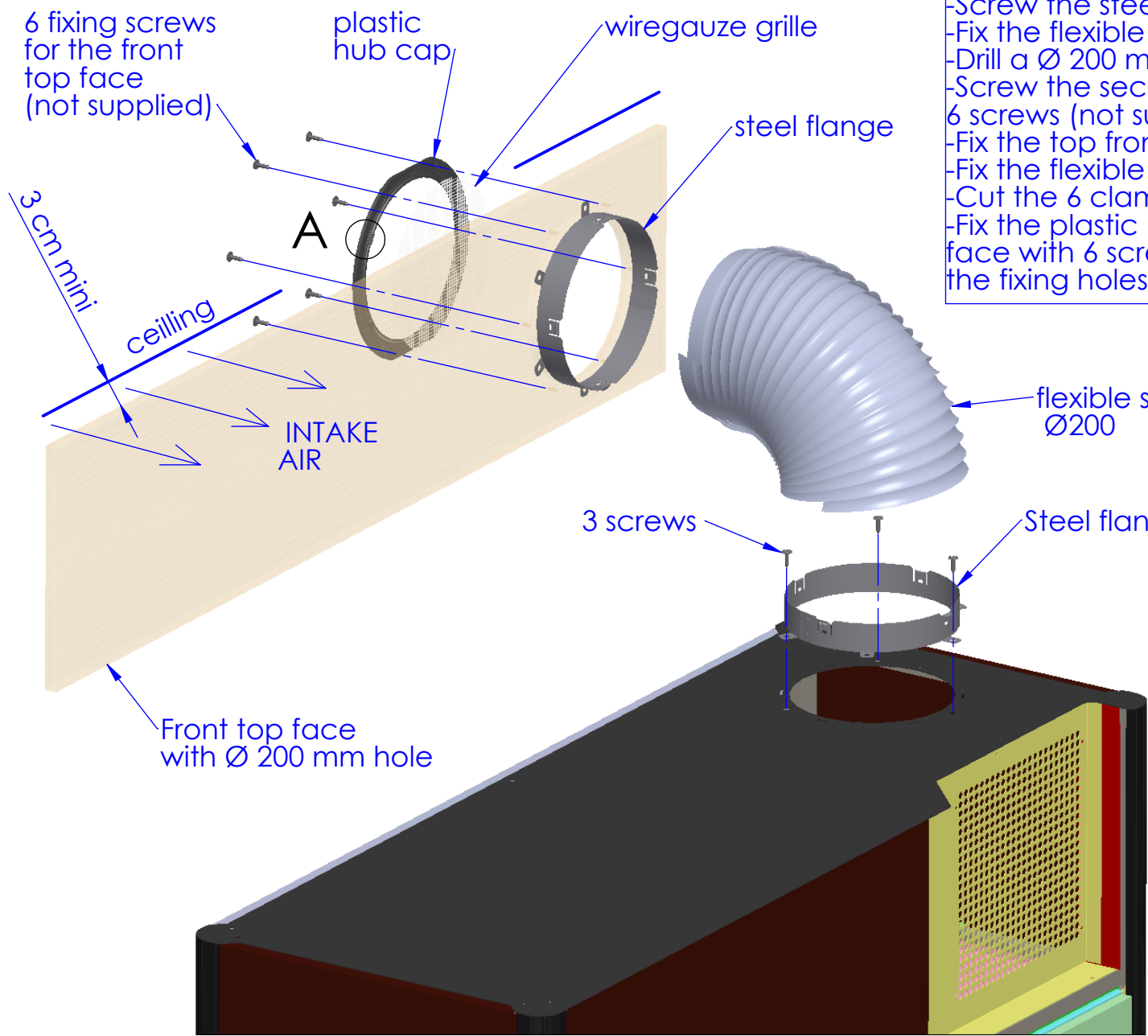

- ASSEMBLY :**
- Unscrew the plastic hub cap and the wiregauze grille from the Showcave unit (3 screws).
  - Screw the steel flange instead of the plastic hub cap.
  - Fix the flexible sleeve on the steel flange.
  - Drill a Ø 200 mm on the top front face.
  - Screw the second steel flange on the top front face with 6 screws (not supplied).
  - Fix the top front face.
  - Fix the flexible sleeve on the second steel flange.
  - Cut the 6 clamps of plastic hub cap.
  - Fix the plastic hub cap and the grille on the top front face with 6 screws ( not supplied). Take care to move up the fixing holes with regard to the steel flange ones.

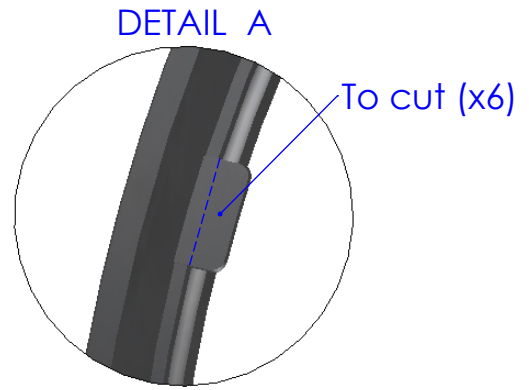

**NOTICE :**  
 Respect a 3 cm airspace intake between the ceiling and the front top face.